

# Bioreactor Configurations

## The bioreactor

a vessel within which a desired conversion of substrate to product is achieved via the biochemical activity of cells or other biologically active agents.

The principles of chemistry, biochemistry, and physics as they pertain to microbiological processes are integrated to give a bioreactor *geometric configuration*.

# Configuration

## Bioreactor configuration

decides how well mechanical power is transformed into

- a series of mass transport steps
- liquid bulk flow phenomena

which are necessary to maintain microbial activity.

# Kinetic Steps in a Bioreaction

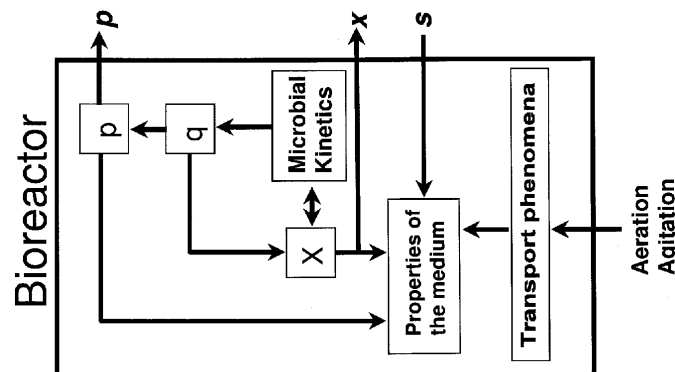

# Desired Properties of Bioreactors

## Functional Requirements

- Creation of gas/liquid interfaces without making foam a problem.
- Sufficient hold-up of dispersed phases.
- Reasonable heat transfer.
- Good control of bulk flow so that "dead" zones can be avoided.

## Economic Requirements

- Cheap, robust and simple mechanical design.
- Asepsis simple to achieve.
- Easy to scale-up.
- Low power consumption.

## Tank baffles

For efficient mixing, turbulent flow is required in a stirred tank bioreactor.

A liquid which is stirred tends to vortex.

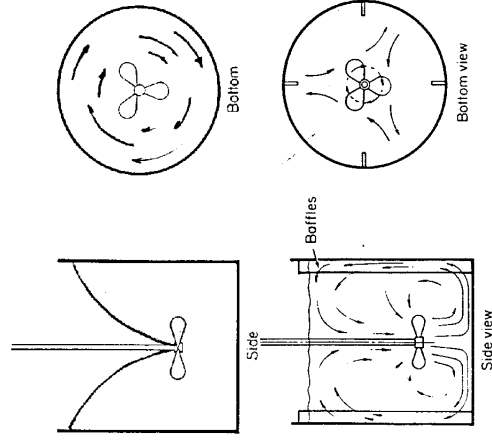

The presence of baffles reduces vortexing and increases the tendency for turbulent flow.

## The Stirred Tank Bioreactor

### Stirred Tank Bioreactors

Characterized by mechanical agitation imparted by impellers on a shaft

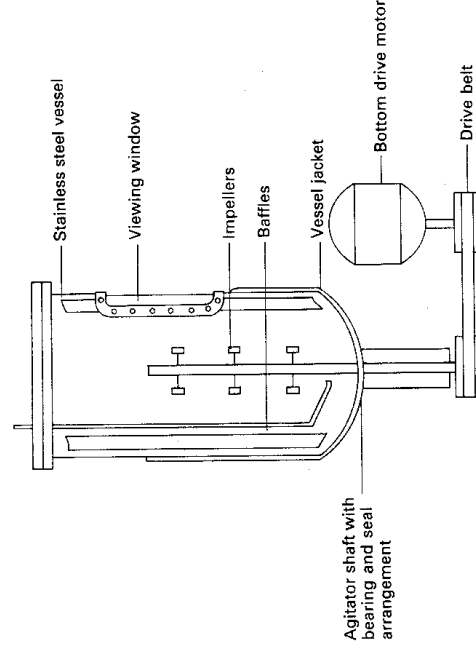

**Main features of a stirred tank bioreactor**  
(Irvine, 1990)

## The Stirred Tank Bioreactor 2

## The Stirred Tank Bioreactor 4

### Advantages

- They are in widespread use.

### Disadvantages

- Impeller agitation generates heat.
- The need for shaft seals and bearings.
- Size limitation by motor size, shaft length and weight.

**The stirred tank bioreactor is configuration most used in industry though there are other configurations. Its use is still widespread probably because**

- The useful life of bioreactors is long.
- Bioreactors are expensive to replace.
- The configuration has become too established in many processes for new methodology to replace.

## Geometric configuration

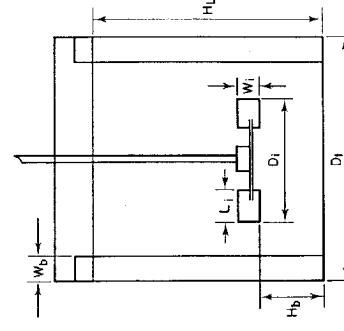

Geometric ratio for standard fermenter

$\frac{D_1}{D_1}$	$\frac{H_A}{D_1}$	$\frac{L_i}{D_1}$	$\frac{W_i}{D_1}$	$\frac{H_b}{D_1}$	$N_b$	$\frac{W_b}{D_1}$
0.33	1.0	0.25	0.2	1.0	4	0.1

Standard fermenter geometry and geometric ratios for stirred tank bioreactors employing flat-blade turbines (Wang *et al.*, 1979)

**The various ratios are optimised for bulk flow and gas/liquid transfer for any given bioreactor volume.**

## The Stirred Tank Bioreactor 3

# Tubular Bioreactors

Characterized by

- a high aspect ratio
- pneumatic agitation

## Generic Groupings

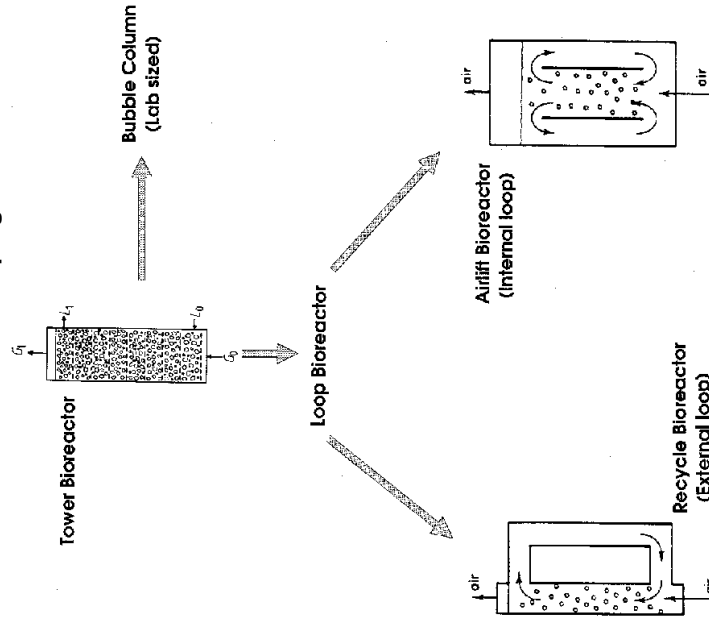

Dr. Clem Kuek

ZIP/Lect+Pracs/IndusMicrobiol/bioreactors.doc

9

# Tubular Bioreactors

## Advantages of pneumatically agitated bioreactors

- No shaft seals.
- Simple design; cheaper to construct. Simpler to scale-up; size not limited by shaft length and weight and motor size.
- Refrigeration requirements are reduced by 20-30% because there is no mechanical agitation.

## Disadvantages

- Working volumes cannot be altered as readily as Stirred Tank Bioreactors.
- Mixing rates are coupled with aeration rates unless gas mixtures can be altered.
- Foam control is potentially a bigger problem than Stirred Tank Bioreactors.

Dr. Clem Kuek

ZIP/Lect+Pracs/IndusMicrobiol/bioreactors.doc

10

# Reactors for Immobilized Enzymes and Microorganisms

**Immobilization:** Where an enzyme or microorganism is attached to an inert carrier, or to each other, or when they are confined within an inert material.

## Fixed Bed Bioreactor

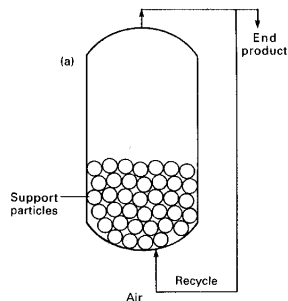

## Fluidized Bed Bioreactor

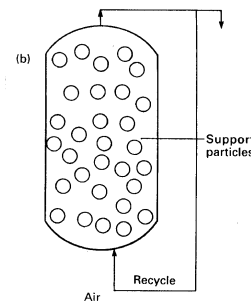

Dr. Clem Kuek

ZIP/Lect+Pracs/IndusMicrobiol/bioreactors.doc

11

# Fixed and Fluidized Bed Bioreactors

## Immobilized enzymes.

Bioreactors for these (and non-viable microorganisms) are simpler because gas/liquid transfer is not a consideration. Used in continuous manner.

## Immobilized living cells.

Bioreactors for these have to allow for gas/liquid transfer. Therefore, fixed beds are rarely used except in anaerobic processes. Used in either batch or continuous manner.

Dr. Clem Kuek

ZIP/Lect+Pracs/IndusMicrobiol/bioreactors.doc







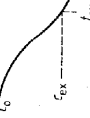
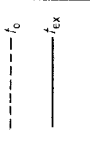
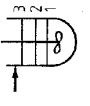
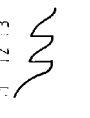

12

# Fixed and Fluidized Bed Bioreactors

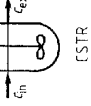
## A comparison

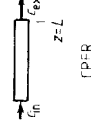
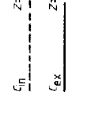
Fixed Bed	Fluidized Bed
1. Throughput determined by: Compressibility of immobilization material.	Density of immobilized aggregation.
2. Channeling can be a problem.	No channeling.
3. Plug flow possible.	Ideal plug flow not possible due to back mixing.

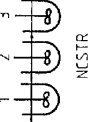
## Operational Modes for Bioreactors

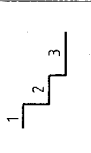
Reactor types (homogeneous)	Concentration profiles $c/t$	Concentration profiles $c/z$
 DCSTR	 $c_0$ $c_{ex}$	 $c_{ex}$
 SCSTR	 $c_0$ $c_{ex}$	 $c_{ex}$
 CSTR	 $c_{ex}$	 $c_{ex}$
 CPEFR	 $c_{in}$ $c_{ex}$	 $c_{in}$ $c_{ex}$ $z=0$ $z=L$
 NCSTR	 $c_{ex}$	 $c_{ex}$

Types of operational modes for, and concentration profiles in bioreactors